

INTEGRATED DOOR PULLS

INTEGRATED DOOR PULLS

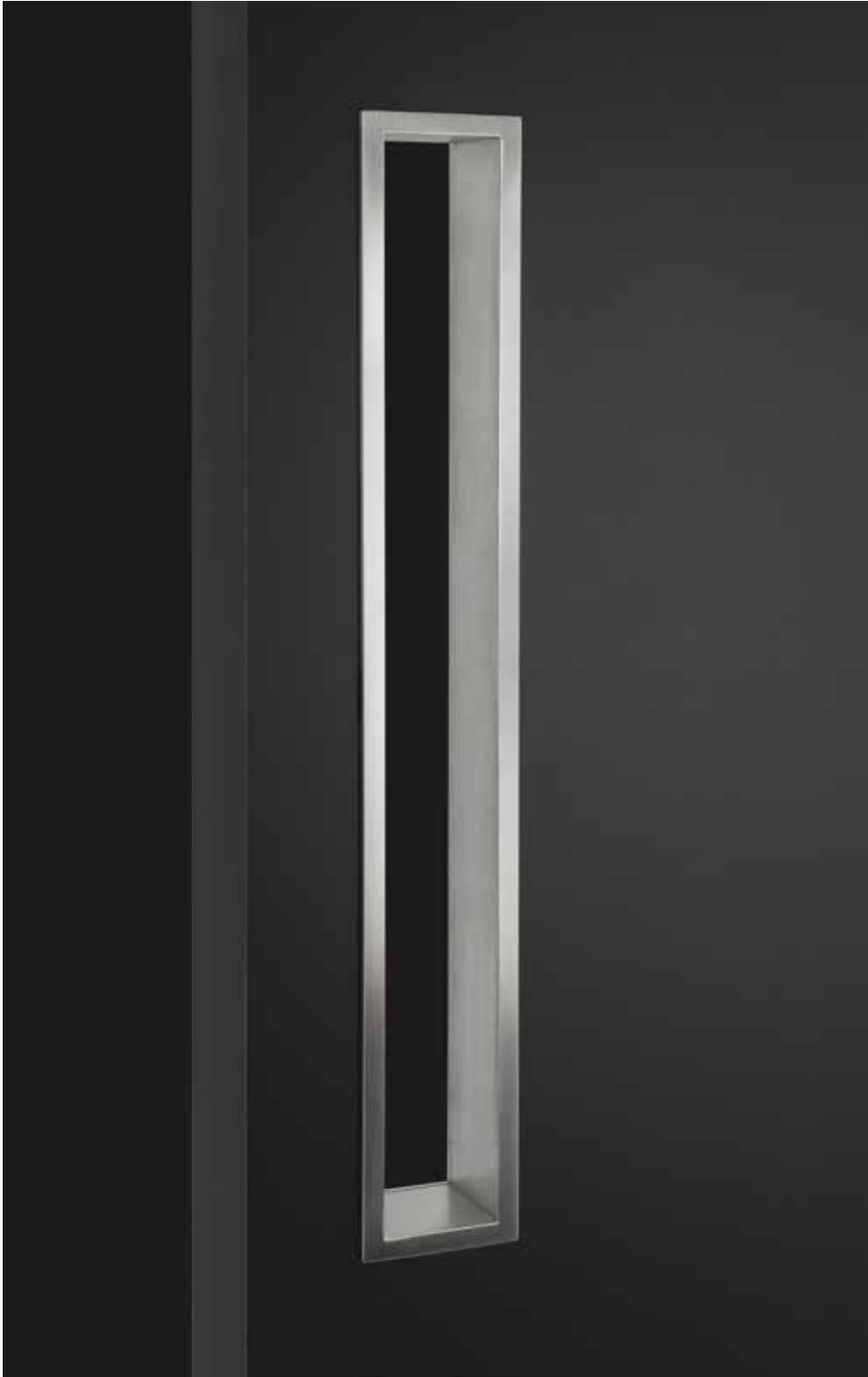

CODE	MATERIAL	FINISH		.XX	* indicative colors
GBD.	STAINLESS STEEL AISI 316L	Standard:	LRV 53	.44	■
		SATIN			
	POWDER-COATED	Black Ral 9005 Matt	.40	■	
		White Ral 9010	.31	□	
		Grey	.32	■	
		Champagne	.38	■	
		Bronze	.39	■	
Screws, grub screws and plastic parts non powder-coated. Available on request depending on quantities.					

DESIGN 1
Stainless Steel AISI 316L

page
Integrated Pulls_6



DESIGN 2
Stainless Steel AISI 316L

page
Integrated Pulls_7



DESIGN 3
Stainless Steel AISI 316L

page
Integrated Pulls_8



DESIGN 4
Stainless Steel AISI 316L

page
Integrated Pulls_9



LEGEND
page Integrated Pulls_3

TECHNICAL REFERENCES
page Integrated Pulls_10



SINGLE DOOR

FACING DOORS

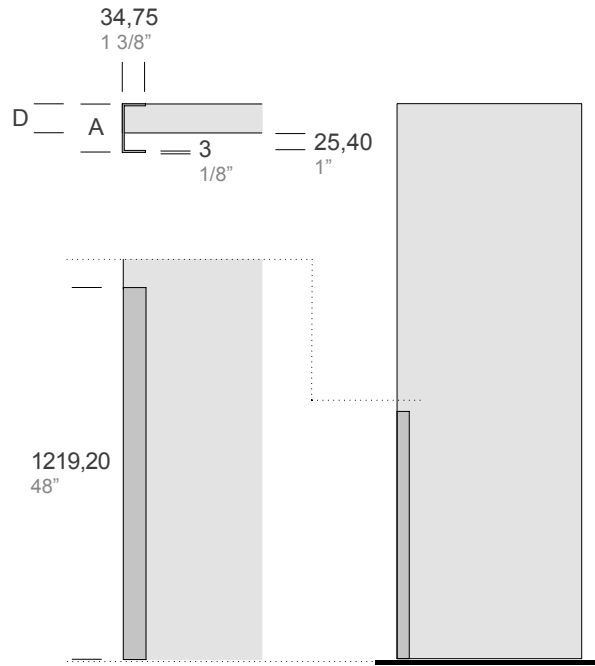

Note:
The size of the required gap between door panels should be determined based on the door thickness, the profile of the leading door edge, and the type and location of the door hinges.

Design 1

ITEM	A	D (DOOR THICKNESS)
GBD.D01.0001 .xx	72,85 mm 2 7/8"	44,45 mm 1 3/4"
GBD.D01.0002 .xx	85,55 mm 3 3/8"	57,15 mm 2 1/4"

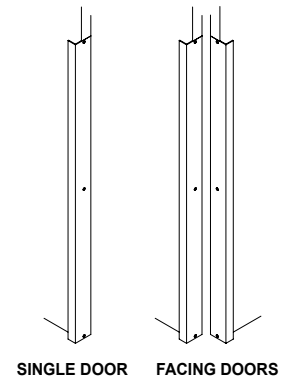

.XX = FINISH CODE

STAINLESS STEEL
.44 SATIN STAINLESS STEEL (ANSI/BHMA 630 - USD32D)

STAINLESS STEEL POWDER-COATED ON REQUEST
.40 BLACK RAL 9005
.31 WHITE RAL 9010
.32 GREY
.38 CHAMPAGNE
.39 BRONZE

WOOD DOOR FIXING KIT INCLUDED:
Stainless Steel fixings for Satin, White, and Champagne finishes;
Black fixings for Bronze, Grey, and Black finishes.

THESE PRODUCTS CONTRIBUTE TO LEED® CREDITS

THE MANUFACTURER RESERVES THE RIGHT TO ALTER, IMPROVE AND DISCONTINUE ANY FEATURES OF THE PRODUCT (MAKE CHANGES AND IMPROVEMENTS IN DESIGNS AND DIMENSIONS) WITHOUT NOTICE.

ALL DIMENSIONS IN THE CATALOG DRAWINGS ARE APPROXIMATIONS. REQUEST THE APPROPRIATE TECHNICAL DRAWING BEFORE DOOR PREPARATION AND INSTALLATION.





SINGLE DOOR

FACING DOORS

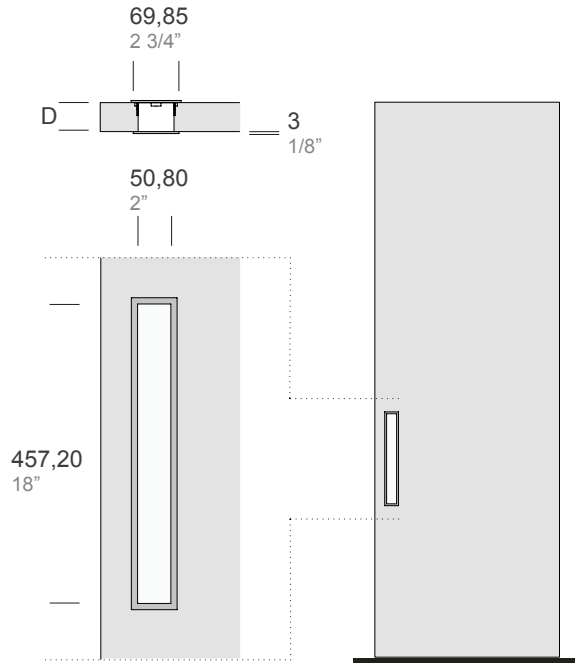

Note:

The size of the required gap between door panels should be determined based on the door thickness, the profile of the leading door edge, and the type and location of the door hinges.

Design 2

ITEM	D (DOOR THICKNESS)
GBD.D02.0001 .xx	44,45 mm 1 3/4"
GBD.D02.0002 .xx	57,15 mm 2 1/4"

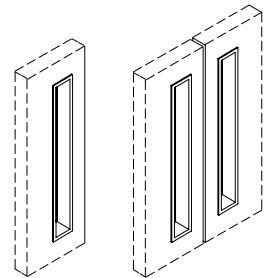

SINGLE DOOR

FACING DOORS

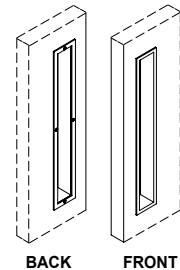

BACK

FRONT

.XX = FINISH CODE

- STAINLESS STEEL
- .44 SATIN STAINLESS STEEL (ANSI/BHMA 630 - USD32D)
- STAINLESS STEEL POWDER-COATED ON REQUEST
- .40 BLACK RAL 9005
- .31 WHITE RAL 9010
- .32 GREY
- .38 CHAMPAGNE
- .39 BRONZE

WOOD DOOR FIXING KIT INCLUDED:
Stainless Steel fixings for Satin, White, and Champagne finishes;
Black fixings for Bronze, Grey, and Black finishes.

THESE PRODUCTS CONTRIBUTE TO LEED® CREDITS

THE MANUFACTURER RESERVES THE RIGHT TO ALTER, IMPROVE AND DISCONTINUE ANY FEATURES OF THE PRODUCT (MAKE CHANGES AND IMPROVEMENTS IN DESIGNS AND DIMENSIONS) WITHOUT NOTICE.

ALL DIMENSIONS IN THE CATALOG DRAWINGS ARE APPROXIMATIONS. REQUEST THE APPROPRIATE TECHNICAL DRAWING BEFORE DOOR PREPARATION AND INSTALLATION.





SINGLE DOOR

FACING DOORS

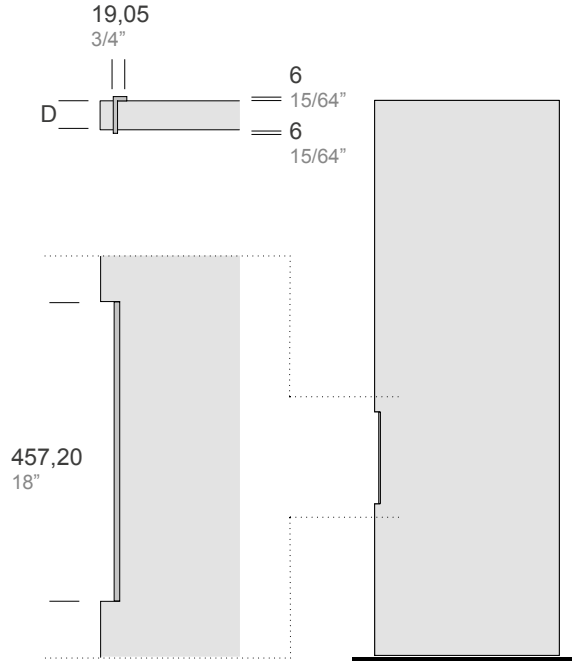

Note:
The size of the required gap between door panels should be determined based on the door thickness, the profile of the leading door edge, and the type and location of the door hinges.

Design 3

ITEM	D (DOOR THICKNESS)
GBD.D03.0001 .xx	44,45 mm 1 3/4"
GBD.D03.0002 .xx	57,15 mm 2 1/4"

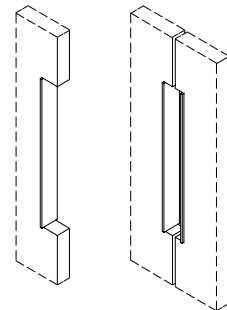

SINGLE DOOR FACING DOORS

SUGGESTED DEPTH FOR USABILITY

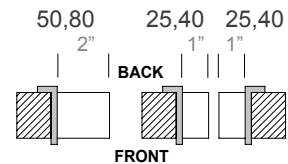

.XX = FINISH CODE

STAINLESS STEEL
.44 SATIN STAINLESS STEEL (ANSI/BHMA 630 - USD32D)

STAINLESS STEEL POWDER-COATED ON REQUEST
.40 BLACK RAL 9005
.31 WHITE RAL 9010
.32 GREY
.38 CHAMPAGNE
.39 BRONZE

WOOD DOOR FIXING KIT INCLUDED:
Stainless Steel fixings for Satin, White, and Champagne finishes;
Black fixings for Bronze, Grey, and Black finishes.

THESE PRODUCTS CONTRIBUTE TO LEED® CREDITS

THE MANUFACTURER RESERVES THE RIGHT TO ALTER, IMPROVE AND DISCONTINUE ANY FEATURES OF THE PRODUCT (MAKE CHANGES AND IMPROVEMENTS IN DESIGNS AND DIMENSIONS) WITHOUT NOTICE.

ALL DIMENSIONS IN THE CATALOG DRAWINGS ARE APPROXIMATIONS. REQUEST THE APPROPRIATE TECHNICAL DRAWING BEFORE DOOR PREPARATION AND INSTALLATION.



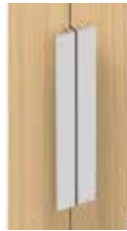

SINGLE DOOR

FACING DOORS

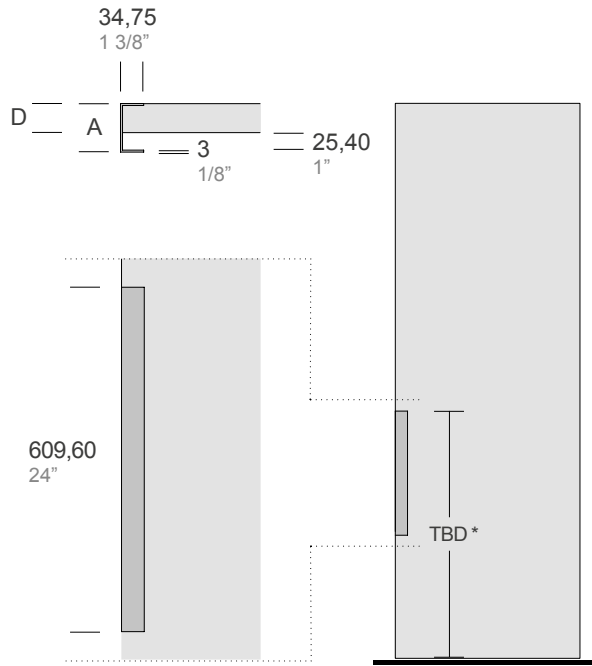

* According to ADA Door and Gate Hardware [§ 404.2.7]

Note:

The size of the required gap between door panels should be determined based on the door thickness, the profile of the leading door edge, and the type and location of the door hinges.

Design 4

ITEM	A	D (DOOR THICKNESS)
GBD.D04.0001 .xx	72,85 mm 2 7/8"	44,45 mm 1 3/4"
GBD.D04.0002 .xx	85,55 mm 3 3/8"	57,15 mm 2 1/4"

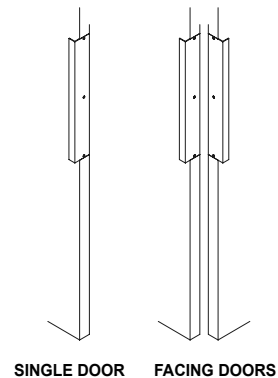

SINGLE DOOR

FACING DOORS

.XX = FINISH CODE

STAINLESS STEEL

.44 SATIN STAINLESS STEEL (ANSI/BHMA 630 - USD32D)

STAINLESS STEEL POWDER-COATED ON REQUEST

- .40 BLACK RAL 9005
- .31 WHITE RAL 9010
- .32 GREY
- .38 CHAMPAGNE
- .39 BRONZE

WOOD DOOR FIXING KIT INCLUDED:
Stainless Steel fixings for Satin, White, and Champagne finishes;
Black fixings for Bronze, Grey, and Black finishes.

THESE PRODUCTS CONTRIBUTE TO LEED® CREDITS

THE MANUFACTURER RESERVES THE RIGHT TO ALTER, IMPROVE AND DISCONTINUE ANY FEATURES OF THE PRODUCT (MAKE CHANGES AND IMPROVEMENTS IN DESIGNS AND DIMENSIONS) WITHOUT NOTICE.

ALL DIMENSIONS IN THE CATALOG DRAWINGS ARE APPROXIMATIONS. REQUEST THE APPROPRIATE TECHNICAL DRAWING BEFORE DOOR PREPARATION AND INSTALLATION.



TECHNICAL INFORMATION

FIXING KIT INCLUDED (WOOD DOOR ONLY)

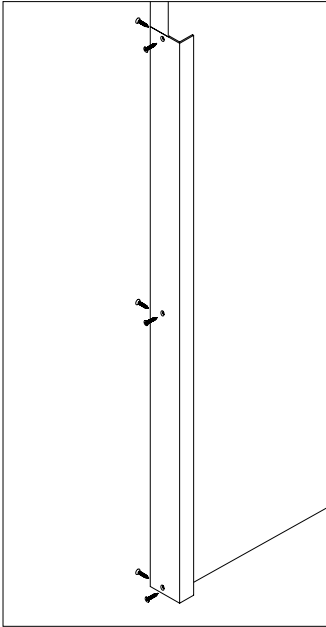

GBD.D01.0001
GBD.D01.0002

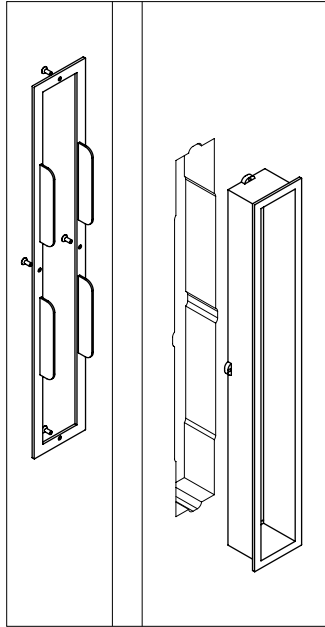

GBD.D02.0001
GBD.D02.0002

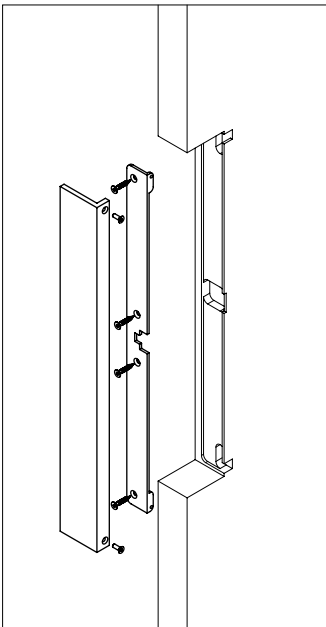

GBD.D03.0001
GBD.D03.0002

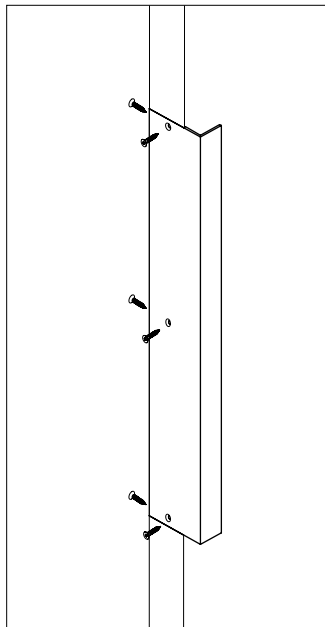

GBD.D04.0001
GBD.D04.0002